

1.6.2.1 Slip-on collars in stainless steel

Table 1.6.2.1_1: Slip-on collars as per DIN EN 1092-1 (formerly DIN 2642), without weld level

Pipe joint dimensions		Collars				
NW/ NB	Outside diameter (mm)	t1 (mm)	t2 (mm)	h4 min. (mm)	d4/ Collar diameter (mm)	Weight (kg)
15	18.0	1.5	2.5	8	45	0.03
	21.3	2.0	3.0	9	45	0.04
20	25.0	2.0	3.0	9	58	0.06
	26.9	2.0	3.0	10	58	0.06
25	30.0	2.0	3.0	12	68	0.09
	31.0	3.0	4.0	12	68	0.12
	33.7	2.0	3.0	12	68	0.09
	33.7	3.0	4.0	12	68	0.12
32	38.0	2.0	3.0	12	78	0.11
	38.0	3.0	4.0	12	78	0.15
	42.4	2.0	3.0	15	78	0.11
	42.4	3.0	4.0	15	78	0.15
40	43.0	1.5	2.5	15	88	0.12
	44.5	2.0	3.0	15	88	0.14
	44.5	2.5	4.0	15	88	0.19
	46.0	3.0	4.0	15	88	0.19
	48.3	2.0	3.0	16	88	0.14
	48.3	2.6	4.0	16	88	0.19
	48.3	3.0	4.0	16	88	0.19
50	53.0	1.5	2.5	18	102	0.16
	54.0	2.0	3.0	18	102	0.19
	56.0	3.0	4.0	18	102	0.25
	57.0	2.0	3.0	18	102	0.19
	57.0	2.5	4.0	18	102	0.25
	57.0	3.0	4.0	18	102	0.25
	60.3	2.0	3.0	21	102	0.19
	60.3	2.5	4.0	21	102	0.25
	60.3	3.0	4.0	21	102	0.25
	60.3	4.0	5.0	21	102	0.31
	65	69.0	2.0	3.0	20	122
70.0		2.0	3.0	20	122	0.26
71.0		3.0	4.0	20	122	0.35
76.1		2.0	3.0	23	122	0.26
76.1		2.6	4.0	23	122	0.35
76.1		3.0	4.0	23	122	0.35
76.1		4.0	5.0	23	122	0.44
80	83.0	1.5	2.5	23	138	0.28
	84.0	2.0	3.0	23	138	0.33
	85.0	2.5	4.0	23	138	0.44
	86.0	3.0	4.0	23	138	0.44
	88.9	2.0	3.0	23	138	0.33
	88.9	2.6	3.5	23	138	0.44
	88.9	3.0	4.0	23	138	0.44
	88.9	4.0	5.0	23	138	0.55

No guarantee for correctness

Continuation >

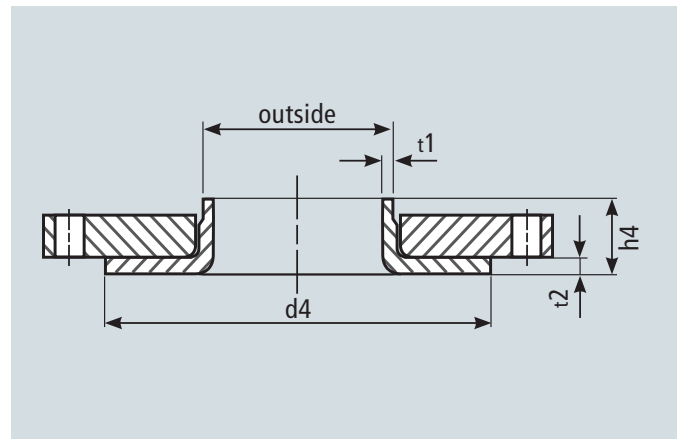

Fig. 1.6.2.1_1: Slip-on collar

Table 1.6.2.1_1: Slip-on collars as per DIN EN 1092-1 (formerly DIN 2642), without weld level (continuation)

Pipe joint dimensions		Collars				
NW/ NB	Outside diameter (mm)	t1 (mm)	t2 (mm)	h4 min. (mm)	d4/ Collar diameter (mm)	Weight (kg)
100	104.0	2.0	3.0	24	158	0.34
	105.0	2.5	3.0	24	158	0.41
	106.0	3.0	4.0	24	158	0.54
	108.0	2.0	3.0	26	158	0.34
	108.0	2.6	3.0	26	158	0.41
	108.0	3.0	4.0	26	158	0.54
	108.0	4.0	5.0	26	158	0.68
	114.3	2.0	3.0	28	158	0.34
	114.3	2.6	3.5	28	158	0.41
	114.3	3.0	4.0	28	158	0.54
	114.3	4.0	5.0	28	158	0.68
	114.3	5.0	6.0	28	158	0.81
	114.3	6.0	7.0	28	158	0.95
	125	129.0	2.0	2.5	25	188
130.0		2.5	3.0	25	188	0.54
131.0		3.0	4.0	25	188	0.72
133.0		2.0	2.5	26	188	0.45
133.0		2.5	3.0	26	188	0.54
133.0		3.0	4.0	26	188	0.72
133.0		4.0	5.0	26	188	0.89
133.0		5.0	6.0	26	188	1.07
139.7		2.0	2.5	30	188	0.45
139.7		2.6	3.5	30	188	0.54
139.7		3.0	4.0	30	188	0.72
139.7		4.0	5.0	30	188	0.89
139.7		5.0	6.0	30	188	1.07

No guarantee for correctness

Continuation >

Table 1.6.2.1_1: Slip-on collars as per DIN EN 1092-1 (formerly DIN 2642), without weld bevel (continuation)

Pipe joint dimensions		Collars				
NW / NB	Outside diameter (mm)	t1 (mm)	t2 (mm)	h4 min. (mm)	d4 / Collar diameter (mm)	Weight (kg)
150	154.0	2.0	2.5	27	212	0.53
	155.0	2.5	3.0	27	212	0.64
	156.0	3.0	4.0	27	212	0.82
	158.0	4.0	5.0	27	212	1.07
	159.0	2.0	2.5	29	212	0.53
	159.0	2.5	3.0	29	212	0.64
	159.0	3.0	4.0	29	212	0.85
	159.0	4.0	5.0	29	212	1.07
	159.0	5.0	6.0	29	212	1.28
	160.0	5.0	6.0	29	212	1.28
	168.3	2.0	2.5	30	212	0.53
	168.3	2.6	3.5	30	212	0.64
	168.3	3.0	4.0	30	212	0.85
	168.3	4.0	5.0	30	212	1.07
	168.3	5.0	6.0	30	212	1.28
	168.3	6.0	7.0	30	212	1.49
175	179.0	2.0	2.5	30	242	0.69
	180.0	2.5	3.0	30	242	0.83
	181.0	3.0	4.0	30	242	1.11
200	204.0	2.0	2.6	30	268	0.65
	205.0	2.5	3.0	30	268	0.78
	206.0	3.0	3.5	30	268	0.94
	208.0	4.0	5.0	30	268	1.57
	210.0	5.0	6.0	30	268	1.88
	216.0	2.0	2.5	30	268	0.94
	216.0	3.0	4.0	30	268	1.25
	216.0	4.0	5.0	30	268	1.57
	216.0	5.0	6.0	30	268	1.88
	219.1	2.0	2.6	30	268	0.78
	219.1	2.5	3.0	30	268	0.94
	219.1	3.0	3.5	30	268	1.25
	219.1	4.0	5.0	30	268	1.57
219.1	5.0	6.0	30	268	1.88	
219.1	6.0	7.0	30	268	2.20	
250	254.0	2.0	2.6	30	320	0.84
	256.0	3.0	3.5	30	320	1.26
	258.0	4.0	5.0	30	320	1.99
	260.0	5.0	6.0	30	320	2.38
	267.0	2.5	3.0	30	320	1.19

Continuation >

Table 1.6.2.1_1: Slip-on collars as per DIN EN 1092-1 (formerly DIN 2642), without weld bevel (continuation)

Pipe joint dimensions		Collars				
NW / NB	Outside diameter (mm)	t1 (mm)	t2 (mm)	h4 min. (mm)	d4 / Collar diameter (mm)	Weight (kg)
250	267.0	3.0	4.0	30	320	1.59
	267.0	4.0	5.0	30	320	1.99
	267.0	5.0	6.0	30	320	2.38
	273.0	2.6	3.5	30	320	1.38
	273.0	3.0	3.5	30	320	1.38
	273.0	4.0	5.0	30	320	1.99
	273.0	5.0	6.0	30	320	2.38
	273.0	6.0	7.0	30	320	2.78
	273.0	7.0	8.0	30	320	3.18
	300	304.0	2.0	2.6	32	370
305.0		2.5	3.0	35	370	1.47
306.0		3.0	3.5	35	370	1.72
308.0		4.0	5.0	35	370	2.46
310.0		5.0	6.0	35	370	2.95
318.0		3.0	4.0	35	370	1.97
318.0		4.0	5.0	35	370	2.46
318.0		5.0	6.0	35	370	2.95
300	323.9	2.0	2.6	35	370	1.23
	323.9	2.6	3.0	35	370	1.48
	323.9	3.0	3.5	35	370	1.75
	323.9	4.0	5.0	35	370	2.46
	323.9	5.0	6.0	35	370	2.95
	323.9	6.0	7.0	35	370	3.45
	323.9	7.0	8.0	35	370	3.94
	323.9	8.0	9.0	35	370	4.43
350	354.0	2.0	2.0	32	430	1.42
	355.0	2.5	2.6	32	430	1.77
	355.6	3.0	3.5	35	430	2.47
	355.6	4.0	5.0	35	430	3.53
	355.6	5.0	5.0	40	430	3.53
	355.6	6.0	6.0	40	430	4.21
	356.0	3.0	3.5	35	430	2.47
	358.0	4.0	4.0	40	430	2.85
	360.0	5.0	5.0	40	430	3.57
	362.0	6.0	6.0	40	430	4.29
	368.0	3.0	3.0	40	430	2.20
	368.0	4.0	4.0	40	430	2.93
	368.0	5.0	5.0	40	430	3.65
	368.0	6.0	6.0	40	430	4.37

Continuation >

No guarantee for correctness

No guarantee for correctness

Table 1.6.2.1_1: Slip-on collars as per DIN EN 1092-1 (formerly DIN 2642), without weld bevel (continuation)

Pipe joint dimensions		Collars				
NW/ NB	Outside diameter (mm)	t1 (mm)	t2 (mm)	h4 min. (mm)	d4/ Collar diameter (mm)	Weight (kg)
400	405.0	2.5	2.5	40	482	2.02
	406.4	3.0	3.5	40	482	2.83
	406.4	4.0	5.0	40	482	4.05
	406.4	5.0	5.0	40	482	4.05
	406.4	6.0	6.0	40	482	4.83
	406.4	7.0	7.0	40	482	5.62
	406.4	8.0	8.0	40	482	6.41
	408.0	4.0	4.0	40	482	3.25
	410.0	5.0	5.0	40	482	4.07
	412.0	6.0	6.0	40	482	4.90
	419.0	3.0	3.0	40	482	2.51
	419.0	4.0	4.0	40	482	3.34
	419.0	5.0	5.0	40	482	4.16
	419.0	6.0	6.0	40	482	4.38
500	506.0	3.0	3.0	45	585	3.22
	508.0	3.0	3.0	45	585	3.24
	508.0	4.0	4.0	45	585	4.31
	508.0	5.0	5.0	45	585	5.37
	508.0	6.0	6.0	45	585	6.43
	510.0	5.0	5.0	45	585	5.31
	512.0	6.0	6.0	45	585	6.48
	450	455.0	2.5	2.5	45	535
456.0		3.0	3.0	45	535	2.73
458.0		4.0	4.0	45	535	3.65
460.0		5.0	5.0	45	535	4.57
462.0		6.0	6.0	45	535	5.50
600	606.0	3.0	3.0	45	685	4.09
	608.0	4.0	4.0	45	685	5.46
	609.6	3.0	3.0	45	685	4.11
	609.6	4.0	4.0	45	685	5.48
	609.6	5.0	5.0	45	685	6.83
	609.6	6.0	6.0	45	685	8.19
	609.6	7.0	7.0	45	685	9.54
	609.6	8.0	8.0	45	685	10.88
	610.0	5.0	5.0	45	685	6.84
	612.0	6.0	6.0	45	685	8.22
	622.0	3.0	3.0	45	685	4.20
	622.0	4.0	4.0	45	685	5.59
	622.0	5.0	5.0	45	685	6.98
	622.0	6.0	6.0	45	685	8.36

Continuation >

Table 1.6.2.1_1: Slip-on collars as per DIN EN 1092-1 (formerly DIN 2642), without weld bevel (continuation)

Pipe joint dimensions		Collars					
NW/ NB	Outside diameter (mm)	t1 (mm)	t2 (mm)	h4 min. (mm)	d4/ Collar diameter (mm)	Weight (kg)	
700	706.0	3.0	3.0	50	800	5.30	
	708.0	4.0	4.0	50	800	7.07	
	710.0	5.0	5.0	50	800	8.86	
	711.2	3.0	3.0	50	800	5.34	
	711.2	4.0	4.0	50	800	7.11	
	711.2	5.0	5.0	50	800	8.87	
	711.2	6.0	6.0	50	800	10.63	
	711.2	7.0	7.0	50	800	12.38	
	711.2	8.0	8.0	50	800	14.13	
	712.0	6.0	6.0	50	800	10.64	
	714.0	7.0	7.0	50	800	12.43	
	716.0	8.0	8.0	50	800	14.23	
	800	806.0	3.0	3.0	50	905	6.05
		808.0	4.0	4.0	50	905	8.08
810.0		5.0	5.0	50	905	10.11	
812.0		6.0	6.0	50	905	12.15	
812.8		3.0	3.0	50	905	6.10	
812.8		4.0	4.0	50	905	8.13	
812.8		5.0	5.0	50	905	10.15	
812.8		6.0	6.0	50	905	12.16	
812.8		7.0	7.0	50	905	14.17	
812.8		8.0	8.0	50	905	16.17	
816.0	8.0	8.0	50	905	16.24		
900	908.0	4.0	4.0	50	1 005	8.66	
	910.0	5.0	5.0	50	1 005	10.11	
	914.4	3.0	3.0	50	1 005	6.54	
	914.4	4.0	4.0	50	1 005	8.72	
	914.4	5.0	5.0	50	1 005	11.48	
	914.4	6.0	6.0	50	1 005	13.78	
914.4	8.0	8.0	50	1 005	18.37		
1 000	1 016.0	3.0	3.0	60	1 110	7.89	
	1 016.0	4.0	4.0	60	1 110	12.62	
	1 016.0	5.0	5.0	60	1 110	13.01	
	1 016.0	6.0	6.0	60	1 110	16.85	
	1 016.0	8.0	8.0	60	1 110	22.47	

No guarantee for correctness

No guarantee for correctness